

TECNIMETAL

TECNIMETAL

Quality Assurance Technology

2-point measurement



TESA
TECHNOLOGY

UNIMASTER model, metric

- MEASUREMENT
 - Internal or external
 - Direct or comparative
 - No need for expensive setting standard thanks to the included standard
 - Constant measuring force for optimal repeatability
- INSTRUMENT
 - Incorporates a dial test indicator for easy detection of the culmination point
 - Interchangeable measuring inserts
 - Ensures stable measuring owing to a negligible deflection of the instrument
 - Thermal protection against hand warmth of the operator
 - Integrated shockproof system
- USE
 - Portable for use on large work pieces that cannot be transported to the laboratory
 - Easy to handle because it can be positioned both horizontally and vertically



01110001

Standard	DIN 863 T4
Measuring range	Vernier: 25 mm Dial gauge: $\pm 0,4$ mm
Max. perm. errors	Measurement element: $5 \mu\text{m}$ + error of each extension + error depending on the number of extensions used Error depending on the number of extensions used 1 extension: $1,1 \mu\text{m}$ 2 extensions: $1,9 \mu\text{m}$ 3 extensions: $4,4 \mu\text{m}$
Resolution	0,01 mm
Material	Inserts: Tungsten Carbide Extensions: Steel
Thread pitch	1 mm
Measuring force	$15 \div 20$ N
Remark(s)	Use of up to 3 extension cables with the measuring element
Included in delivery	Measuring element Extensions Masterpiece Measuring inserts Calibration certificate for the setting standard Measurement report for the measuring element Measurement report for each extension Declaration of conformity User manual

Large dimensions measurement

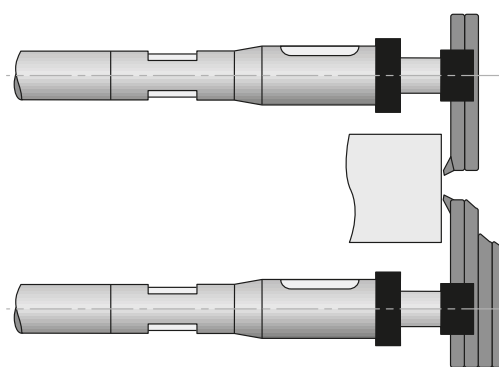
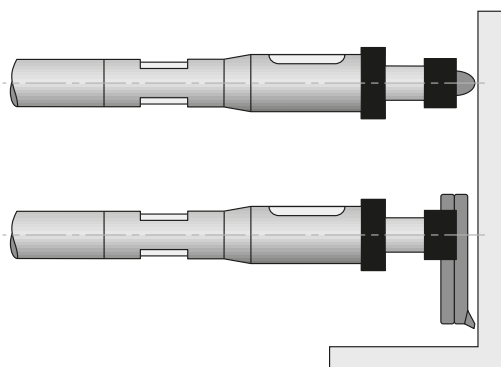

Article number	Designation	Application range mm
01110000	UNIMASTER, set without 1000 mm extension	Internal: 250 ÷ 1625, external: 225 ÷ 1600
01110001	UNIMASTER, set with 1000 mm extension	Internal: 250 ÷ 2325, external: 225 ÷ 2300

Accessories

Article number	Designation
01112401	UNIMASTER wheeled case
01130001	Screwdriver UNIMASTER

UNIMASTER sets

Article number	Description	Measurement	01110000	01110001
01110300	Measurement element	Internal: 250 ÷ 275 mm External: 225 ÷ 250 mm	•	•
01110101	Extension, L = 25 mm		•	•
01110102	Extension, L = 50 mm		•	•
01110103	Extension, L = 75 mm		•	•
01110104	Extension, L = 100 mm		•	•
01110105	Extension, L = 125 mm		•	•
01110106	Extension, L = 150 mm		•	•
01110112	Extension, L = 300 mm		•	•
01110118	Extension, L = 450 mm		•	•
01110124	Extension, L = 600 mm		•	•
01110140	Extension, L = 1000 mm			•
01110203	Pair of inserts	Internal	•	•
01110205	Pair of inserts, L = 75 mm	Internal External	•	•
01110208	Pair of inserts, L = 100 mm	Internal External	•	•
01110501	Setting standard	Internal: 250 mm External: 225 mm	•	•
01130001	Screwdriver		•	•
01110401	Set of suspension accessories (4 brackets and 4 clamps)		•	•
01112401	Wheeled case		•	•

Extensions for UNIMASTER

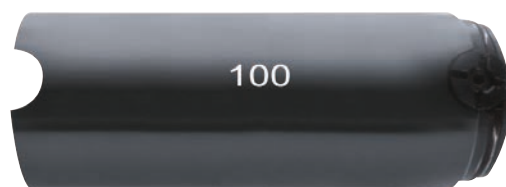

01110104

Max. perm. errors	<p>Measurement element: 5 μm + error of each extension + error depending on the number of extensions used</p> <p>Error depending on the number of extensions used 1 extension: 1,1 μm 2 extensions: 1,9 μm 3 extensions: 4,4 μm</p>
Material	Steel
Diameter	\varnothing 38 mm
Remark(s)	Use of up to 3 extension cables with the measuring element
Included in delivery	Extension Calibration certificate

Article number	Designation	Max. perm. errors μm
01110101	UNIMASTER extension, L = 25 mm	0,7
01110102	UNIMASTER extension, L = 50 mm	1
01110103	UNIMASTER extension, L = 75 mm	1,2
01110104	UNIMASTER extension, L = 100 mm	1,5
01110105	UNIMASTER extension, L = 125 mm	1,5
01110106	UNIMASTER extension, L = 150 mm	2
01110112	UNIMASTER extension, L = 300 mm	3,5
01110118	UNIMASTER extension, L = 450 mm	4,5
01110124	UNIMASTER extension, L = 600 mm	6,5
01110140	UNIMASTER extension, L = 1000 mm	10

Large dimensions measurement

Measuring bolts for UNIMASTER

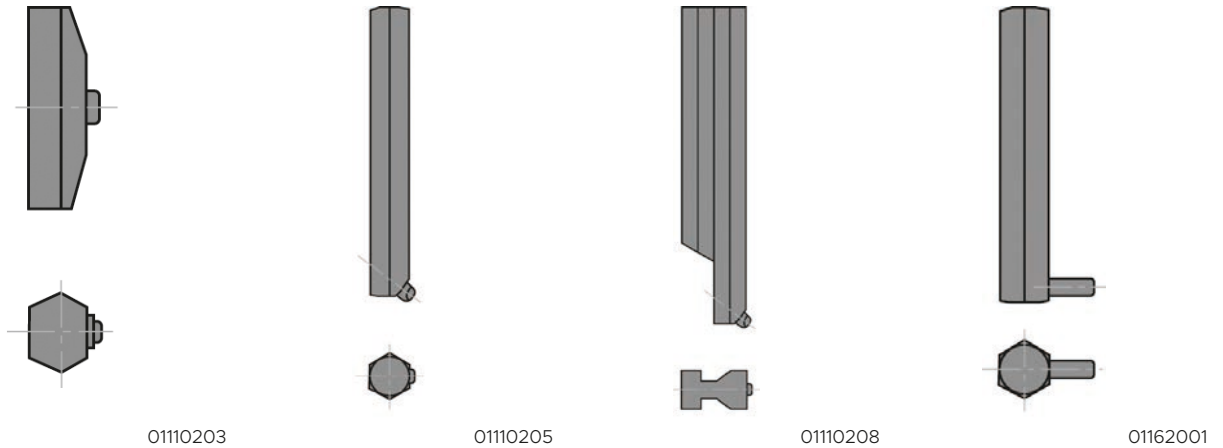

Article number	Designation
01110203	Pair of inserts for internal measurement
01110205	Pair of inserts for internal and external measurement, L = 75 mm
01110208	Pair of inserts for internal and external measurement, L = 100 mm
01162001	Pair of inserts for internal, external and grooves measurement, depth ≤ 20 mm, Ø 4 x 7 mm

Other accessories for UNIMASTER



Article number	Designation
01110401	Set of suspension accessories (4 brackets and 4 clamps)
01160001	Roller (2 items are needed)